

MARX GENERATOR USING PSEUDOSPARK SWITCHES *

Andras Kuthi, Ray Alde, and Martin Gundersen^ξ,
Department of Electrical Engineering – Electrophysics
University of Southern California
Los Angeles, CA 90089-0271

Andreas Neuber
Department of Electrical & Computer Engineering
Texas Tech University
Lubbock, TX 79409-3102

Abstract

The design and preliminary operation of the major subsystems of a Marx style pulse generator using advanced Pseudospark devices are presented. The bank consists of three 150nF / 40kV capacitors connected with three floating FS2000 type Pseudospark switches. These switches can hold off 35 kV and pass up to 10 kA at repetition rates approaching 1 kHz. The expected lifetime of >200kC and the relatively low housekeeping power of <50 W make the Pseudospark switch an excellent candidate in compact Marx generator applications. Preliminary operation of the floating housekeeping units essential to the Marx generator is presented in detail.

I. INTRODUCTION

There is a need for high voltage, high current, compact pulsed power sources at the 500 kV, 10 kA, and 500 ns parameter level. Few switches can handle such parameters with any reliability. We have taken two distinct approaches to such a compact pulse generator system. The first is based on the development of a multi-gap, 200 kV rated Pseudospark switch and Transmission Line Transformers [1], and the other, which we present here, is the Marx generator. Switches in Marx generators need to hold off only a single stage voltage.

Traditionally, pressurized spark gaps and Thyratrons have been used as high power Marx-bank switches. Spark gaps suffer from limited lifetime, low repetition rate and erratic trigger performance, although modern versions have built in UV preionization aiding in trigger reliability. Thyratrons have much longer life, faster switch recovery and precise, low-jitter triggering. However, they suffer

from low current capability, large size and very high housekeeping power, making the Marx generator large and expensive, mostly due to the floating housekeeping power requirement.

An excellent candidate switch is the Pseudospark [2,3,4,5]. The Pseudospark is a glow discharge switch, capable of operation at 35 kV and 10 kA, having fast (< 30 nS) rise time, small size and relatively low housekeeping power requirement. Although an optically triggered version of the Pseudospark, called Back Lighted Thyatron (BLT), had been used in a small prototype Marx bank and proved to have the requisite low jitter and short rise time [6], the presence of optical fiber inside the hollow cathode cavity of the switch in contact with high density plasma during the switch on-time made this arrangement prone to impurity induced failure. Further development of the optical trigger system is expected to lead to a superior switch, but presently the only available commercial Pseudospark is based on electrical trigger.

Electrically triggered Pseudosparks can achieve, under optimized conditions, subnanosecond jitter and delays on the order of tens of nanoseconds [7]. After a large number ($\sim 10^7$) of pulses, the jitter usually increases to 10 – 20 ns, due to electrode erosion. In the Marx bank application the important issues to be resolved are the stability and reproducibility of delay and jitter among all the switches and the practicality of a highly efficient, compact floating power supplied to each switch. These are interrelated issues, as the delay is a strong function of the trigger pulse shape and amplitude as well as of the exact gas pressure inside the switches. Thus, the main design and implementation problem lies in the floating housekeeping power units of each switch.

In order to examine these issues we have designed and constructed a three stage Marx generator using the

* This work was primarily funded by the Compact-Pulsed Power MURI program funded by the Director of Defense Research and Engineering (DDR&E) and managed by the Air Force Office of Scientific Research (AFOSR) and was also funded by the Army Research Office (ARO).

^ξ email: mgu@usc.edu

commercial FS2000 Pseudospark switch. Isolated floating power is supplied to the switches by a novel high frequency and high efficiency Class-E power converter [8]. The floating trigger generators are of a flyback design [9]. Individual trigger signals are passed to the floating units by optical fibers. The gas pressure control is feedback stabilized, using optical signal isolation.

II. DESIGN

The Marx bank is designed around the commercially available FS2000 type Pseudospark switch shown in Fig. 1. The FS2000 can hold off 35 kV and pass up to 10 kA at repetition rates approaching 1 kHz. The expected switch lifetime is >200 kC. The compact Marx generator is housed in an oil filled steel container of dimensions 46 cm x 92 cm x 46 cm.

Absolute maximum housekeeping requirements are the following: Gas reservoir heater = 4 V and 5 A; Keep alive discharge = -2 kV and 2 mA; Trigger power supply = 10 W.

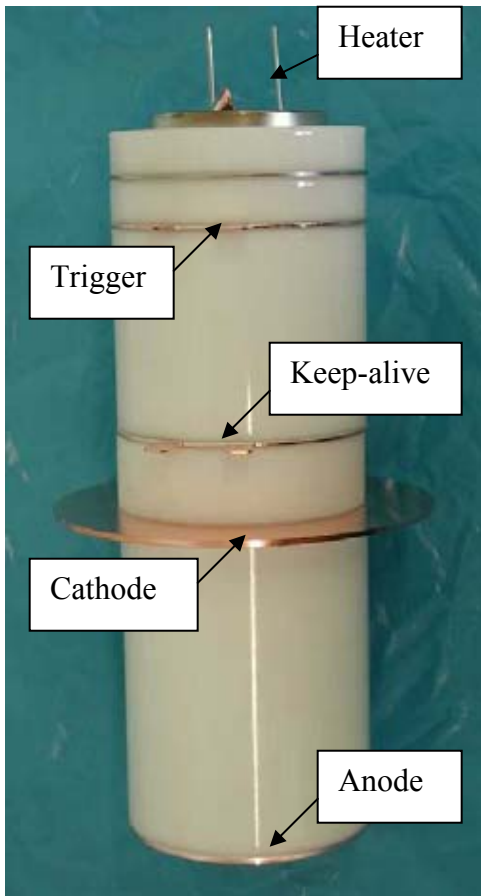

Figure 1. The FS2000 Pseudospark switch: length = 173 mm, cathode flange diameter = 92 mm

In order to test the system at maximum switch capacity a three stage Marx bank with 30 kV per stage was

selected. The peak output voltage of the generator is then 90 kV. The maximum switch current of 9 kA leads to a load impedance of 10 Ω. The test load is an 18" long Kanthal-Global ceramic resistor.

The bank architecture is grounded first switch, negative output type as shown in Fig. 2. In this bank all capacitors float, but the first switch cathode is at ground potential. Thus, the floating switches only have to be insulated for 30 kV, respective 60 kV, and not for the full bank output of 90 kV.

The intermediate charging resistors are 1 kΩ, 8" long ceramic resistors. The main charging resistor is 500 kΩ. The energy storage elements are 150 nF / 40 kV oil filled plastic HV capacitors manufactured by Maxwell. The erected bank capacitance of 50 nF and the 10 Ω load resistance determine the 500 ns pulse length.

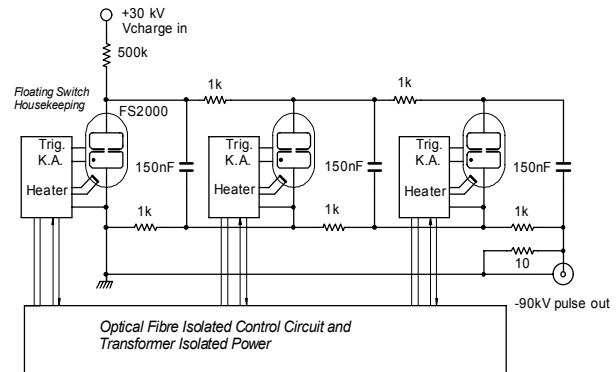

Figure 2. Marx-Generator with Pseudospark Switches

A. Housekeeping

Although the first switch cathode is directly grounded we decided to use even here a floating housekeeping power supply, identical to the other two stages (Fig. 3). The reason is that at the 10 kA load current level it is very difficult to avoid ground noise interference with the control and diagnostic circuits if a direct ground connection exists between the low current, low voltage control and the high current bank circuits.

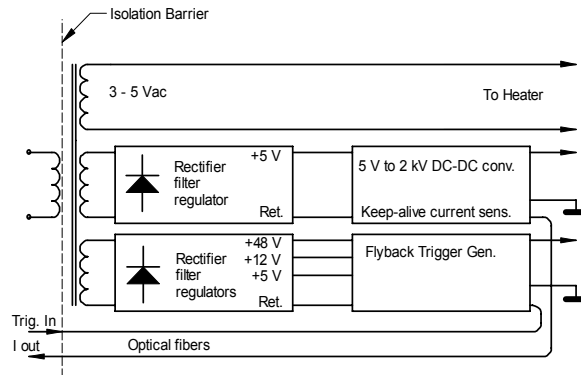

Figure 3. Block diagram of the floating housekeeping system

The entire housekeeping system fits into an aluminum box of dimensions 7.9 cm x 16.6 cm x 15.2 cm, enclosing the cathode side of the Pseudospark switch as well as shown in Figure 4.

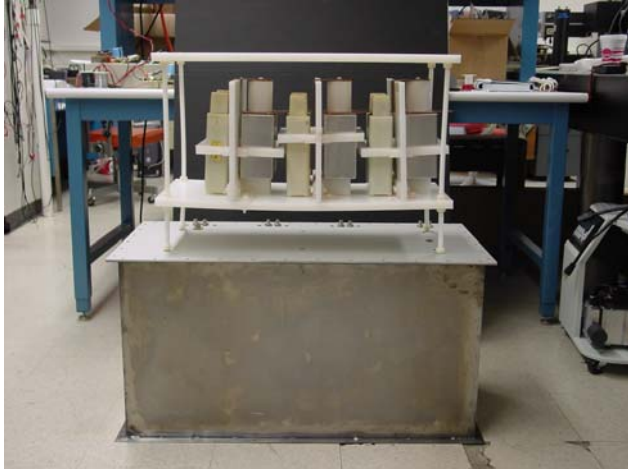

Figure 4. The Marx bank and its components

Local floating housekeeping power for each switch is provided by a high frequency isolation transformer. The transformer is wound on a ferrite toroid core, 3.5 cm ID, 6 cm OD, 1.27 cm high, 3F4 material. The primary winding is 10 turns of 40 kV silicon insulated wire. This primary winding is the main HV insulation barrier. There are a set of three secondary windings: 2 x 5 turns of 18 awg magnet wire, bifilar wound, for the heater; 6 turns of 18 awg wire for the keep alive power; and 40 turns of 22 awg wire for the trigger supply.

The Flyback trigger circuit is shown in Fig. 5. In this configuration the trigger MOSFET switch is off when the Pseudospark fires, and so the return flash from the trigger electrode does not affect the circuit. Rapid and hard turn-off of the MOSFET is assured by the P-channel shorting switch across the main MOSFET gate. The optical fiber receiver and MOSFET gate driver are of standard design and are not shown.

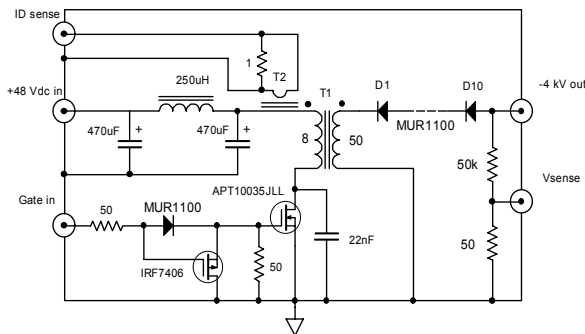

Figure 5. The Flyback trigger circuit

The keep-alive power, -2 kV at ~ 1 mA, is generated by a commercial DC to DC converter, model 5VV2 from PICO Electronics. This unit is small, efficient and fits into the limited space available in the housekeeping

enclosure attached to the Pseudospark switch. The keep-alive current is used as a pressure gauge. The current is sensed by a resistor, and is converted into a 0 – 10 mA signal through a LED transmitter as shown in Figure 6. The analog optical signal is passed through an optical fiber across the isolation barrier to an optical receiver on the main control board.

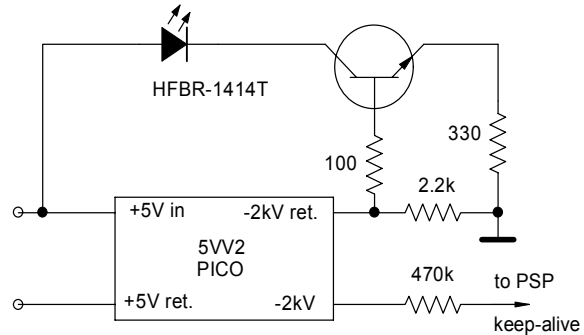

Figure 6. The keep-alive current sense circuit

B. Power Converter

The main power converter is a Class-E tuned switching amplifier. The characteristics of this class of RF amplifiers is that the switching element, in our case a 1000 V, 100 A rated MOSFET, turns on at the moment when the drain voltage is zero, so there is no dissipation associated with the discharging of the drain capacitance. This is accomplished by a resonant load network (Fig. 7).

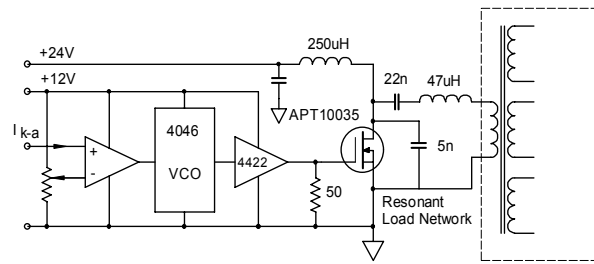

Figure 7. The Class-E power converter

The transformer with its leakage inductance is part of the load network, so is the MOSFET's intrinsic drain capacitance. Thus, the parasitic elements of the major components of the circuit are working with, not against the design. Figure 8 shows the return of the drain voltage to zero at the turn-on of the MOSFET, at both full power and at minimum power to the Pseudospark heater. The heater waveform is shown in Figure 9.

The range of operating frequency is 150 KHz at maximum power to 200 kHz at minimum. Heater power varies more than a factor 4 over this range. The efficiency of the power converter and transformer system is better than 85% over the full power range.

On the secondary side of the transformer Schottky rectifiers must be used due to the high operating frequency. Losses contributed by inferior fast rectifiers can be significant and may lead to rectifier failure.

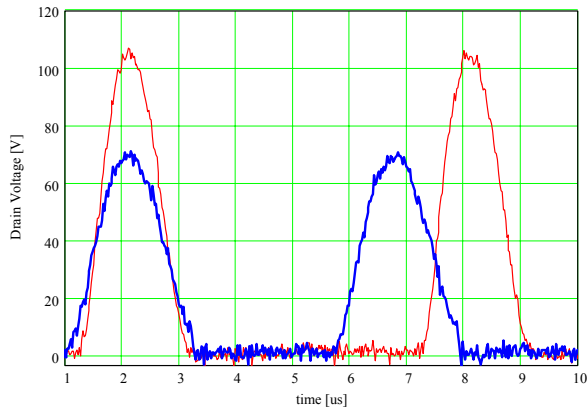

Figure 8. The MOSFET drain voltage waveform indicating well tuned Class-E operation

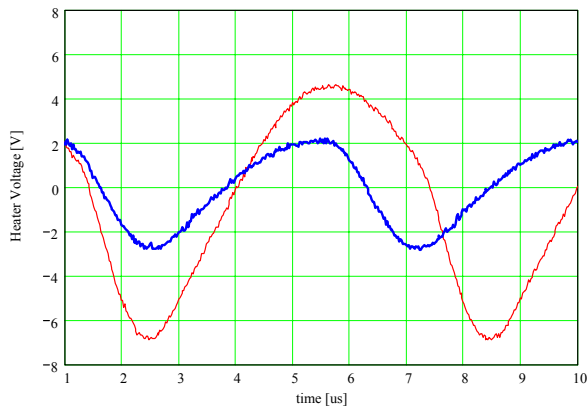

Figure 9. The heater voltage at minimum and at full load

The drive signal to the MOSFET switch is generated by a Voltage-Controlled Oscillator (VCO). The frequency, and thus the heater power, can be adjusted automatically by keeping the keep-alive current of the Pseudospark constant, closing an optical fiber based feedback loop.

To date, the power converter, keep-alive and trigger circuits have been built and tested. Individual Pseudospark switches have been tested as well; currents of 8 kA at 30 kV have been achieved with a rise time of 35 ns. The main Marx bank is under construction and is expected to be fully operational in the near future.

III. SUMMARY

We have described the design, construction and preliminary operation of the major subsystems of a Pseudospark switch based Marx generator. The floating power supplies and optical fiber based trigger and feedback control circuits essential to the Pseudospark operation in a Marx configuration are described in detail. Reliable long life operation is made possible by the pseudospark switch.

IV. REFERENCES

- [1] Ian D. Smith, "A novel voltage multiplication scheme using transmission lines" Proc. 15th IEEE Power Modulator Symposium, 223-226, (1982).
- [2] K. Frank, E. Boggasch, J. Christiansen, A. Goertler, W. Hartmann, C. Kozlik, G. Kirkman, C. G. Braun, V. Dominic, M.A. Gundersen, H. Riege and G. Mechtersheimer, "High power pseudospark and BLT switches," IEEE Trans. Plasma Science **16** (2), 317 (1988).
- [3] "The Physics and Applications of Pseudosparks," NATO ASI Series B **219**, Plenum Press (1990)
- [4] G. Kirkman-Amemiya, H. Bauer, R. L. Liou, T. Y. Hsu, H. Figueroa, and M. A. Gundersen, "A study of the high-current back-lighted thyratron and pseudospark switch," Proceedings of the Nineteenth Power Modulator Symposium, 254 (1990).
- [5] M. Gundersen and G. Roth, "High power switches," in "The Handbook of Accelerator Physics and Engineering," Eds. A. Chao and Maury Tigner, World Scientific Publishing Co. (1999).
- [6] R. Liou, H. Figueroa, Y. Hsu, G. Kirkman and M.A. Gundersen, "An Optically Triggered, Glow Switch Marx Bank," IEEE Trans. on Electron Dev. **37** (6) 1591 (1990).
- [7] L.C. Pitchford, N. Ouadoudi, J.P. Baeuf, M. Legentil, V. Puech, J.C. Thomaz, Jr. and M.A. Gundersen, "Triggered Breakdown in Low-Pressure Hollow-Cathode (Pseudospark) Discharges," J. Appl. Phys., **78** (1) 77 (1995).
- [8] J. Ebert and M. Kazimierczuk, "Class E High-Efficiency Tuned Power Oscillator," IEEE J. of Solid State Circuits, **SC-16** (2) 62 (1981).
- [9] A. Kuthi, T. Vernier, X. Gu, and M. A. Gundersen, "Compact Nanosecond Pulse Generator for Cell Electroperturbation Experiments," Proc. of 25th IEEE International Power Modulator Conference,, pps. 354 – 357 (2002).